

- 1
- 2
- 3
- 4
- 5

**FULLY-FINISHED ADAPTER PLATES FOR
4304, 4305, 4306, 4307**

8217-0
TYPE A

I

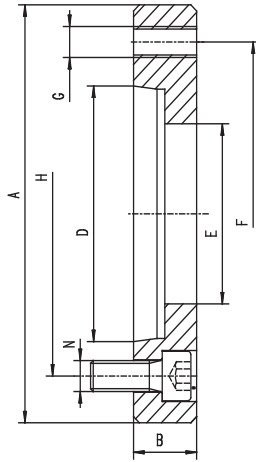

II

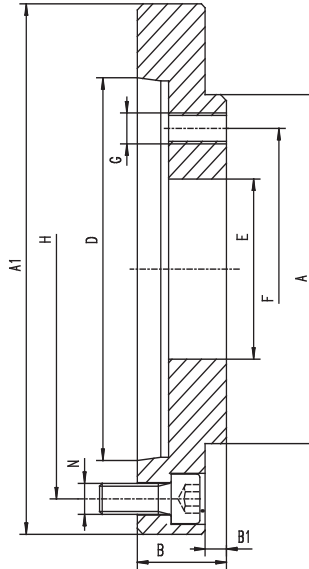

W - Chuck diameter Z - adapter form

Code No.	W*	Taper Size	Z*	A h6 [in]	A1 [in]	B [in]	B1 [in]	D [in]	E [in]	F [in]	G	H [in]	N	Weight [lbs]
7-933-084	8"	4	I	4.33	-	1.10	-	2.50	1.97	3.25	M10	3.25	4xM10	3.31
7-933-085	8"	5	II	4.33	5.24	1.50	0.22	3.25	1.97	3.25	M10	4.13	6xM10	6.17
7-933-086	8"	6	II	4.33	6.50	1.26	0.22	4.19	1.97	3.25	M10	5.25	6xM12	7.72
7-933-105	10"	5	I	5.91	-	1.06	-	3.25	2.56	4.13	M12	4.13	8xM10	5.73
7-933-106	10"	6	II	5.91	6.50	1.57	0.30	4.19	2.56	4.13	M12	5.25	6xM12	9.70
7-933-108	10"	8	II	5.91	8.27	1.50	0.30	5.50	2.56	4.13	M12	6.75	6xM16	14.33
7-933-125	12"	5	I	6.89	-	1.18	-	3.25	3.11	5.25	M16	4.13	6xM10	9.26
7-933-126	12"	6	I	6.89	-	1.38	-	4.19	3.15	5.25	M16	5.25	8xM12	9.92
7-933-128	12"	8	II	6.89	8.27	2.05	0.30	5.50	3.15	5.25	M16	6.75	6xM16	20.94
7-933-129	12"	11	II	6.89	11.02	1.93	0.30	7.75	3.15	5.25	M16	9.25	6xM20	30.86
7-933-166	16"	6	I	7.87	-	1.18	-	4.19	4.06	6.75	M16	5.25	8xM12	11.24
7-933-168	16"	8	II	7.87	8.27	1.18	-	5.50	3.94	6.75	M16	6.75	6xM16	10.58
7-933-169	16"	11	II	7.87	11.02	1.77	0.41	7.75	3.94	6.75	M16	9.25	6xM20	27.78
7-933-175	16"	15	II	7.87	14.96	2.56	0.41	11.25	3.94	6.75	M16	13.00	6xM24	64.15
7-933-206	20"	6	I	10.63	-	1.18	-	4.19	4.06	9.25	M20	5.25	6xM12	23.81
7-933-208	20"	8	I	10.63	-	1.38	-	5.50	4.92	9.25	M20	6.75	6xM16	24.69
7-933-209	20"	11	II	10.63	11.02	1.57	0.49	7.75	4.92	9.25	M20	9.25	6xM20	25.35
7-933-215	20"	15	II	10.63	14.96	2.05	0.49	11.25	4.92	9.25	M20	13.00	6xM24	58.86
7-933-258	25"	8	I	10.63	-	1.26	-	5.50	5.35	9.25	M20	6.75	6xM16	22.27
7-933-259	25"	11	II	10.63	11.02	1.50	-	7.75	6.30	9.25	M20	9.25	6xM20	21.61
7-933-265	25"	15	II	10.63	14.96	2.15	0.49	11.25	6.30	9.25	M20	13.00	6xM24	59.08