

FULLY-FINISHED ADAPTER PLATES FOR
4306, 4307, 32**, 35**, 36**, 37**, 38**

8237-1
TYPE C

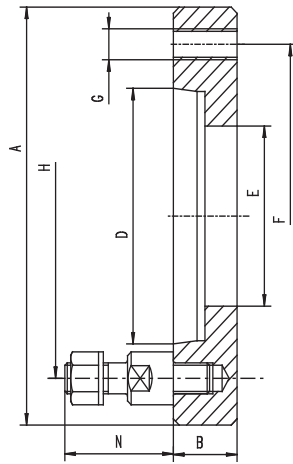

I



II

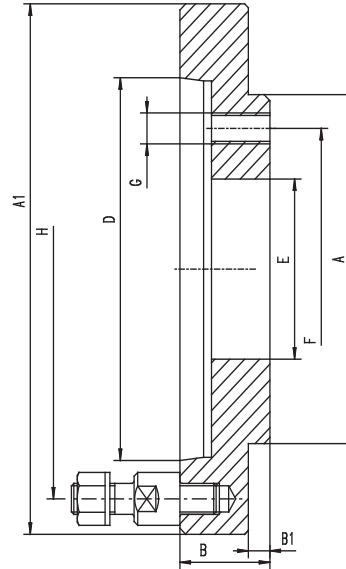

W - Chuck diameter Z - adapter form

Code No.	W*	Taper Size	Z*	A h6 [in]	A1 [in]	B [in]	B1 [in]	D [in]	E [in]	F [in]	G	H [in]	N [in]	No. of studs	Weight [lbs]
7-931-328	32"	8	I	14.96	-	1.50	-	5.50	5.36	13.00	12xM24	6.75	2.36	4	66.14
7-931-329	32"	11	I	14.96	-	1.57	-	7.75	7.59	13.00	12xM24	9.25	2.95	6	55.78
7-931-335	32"	15	II	14.96	15.75	1.57	0.51	11.25	11.08	13.00	12xM24	13.00	3.54	6	44.97
7-931-338	32"	8	I	17.72	-	1.50	-	5.50	5.36	14.50	12xM24	6.75	2.36	4	95.90
7-931-339	32"	11	I	17.72	-	1.50	-	7.75	7.59	14.50	12xM24	9.25	2.95	6	84.66
7-931-345	32"	15	I	17.72	-	1.57	-	11.25	11.08	14.50	12xM24	13.00	3.54	6	71.21
7-931-409	40"; 49"	11	I	20.47	-	1.57	-	7.75	7.59	18.25	12xM24	9.25	2.95	6	120.15
7-931-415	40"; 49"	15	I	20.47	-	1.57	-	11.25	11.08	18.25	12xM24	13.00	3.54	6	106.48
7-931-420	40"; 49"	20	II	20.47	21.26	0.55	-	16.25	16.06	18.25	12xM24	18.25	3.94	6	70.99
7-931-499	49"	11	I	28.35	-	1.97	-	7.75	7.59	25.50	12xM30	9.25	2.95	6	304.24
7-931-505	49"	15	I	28.35	-	1.97	-	11.25	11.08	25.50	12xM30	13.00	3.54	6	291.01
7-931-492	49"	20	I	28.35	-	1.97	-	16.25	16.06	25.50	12xM30	18.25	3.94	6	234.79