



4-JAW INDEPENDENT CHUCKS

- EXTRA HEAVY DUTY WITH LARGE THROUGH-HOLE
- D-TYPE DIRECT MOUNT



4347 HD

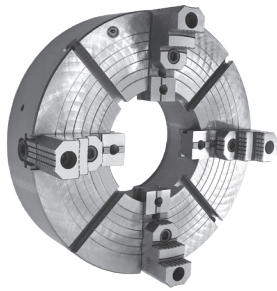

Standard accessories



1 Set of hard top jaws



1 Set of hard master jaws



1 Wrench

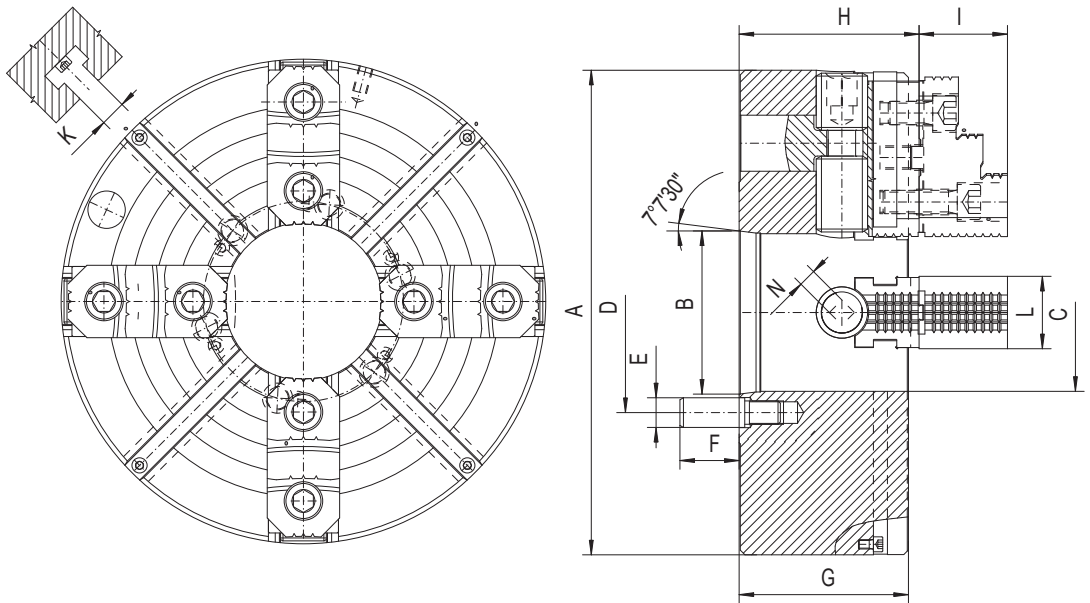

- BISON OIL COUNTRY CHUCKS HD with large through-holes are designed for gripping long and heavy workpieces or pipes during heavy-duty (HD) machining
- High gripping force
- High accuracy
- Heavy-duty operations
- Chucks can work individually or in pairs, mounted on opposite sides of the lathe spindle

Code No.	Type	A [in]	Taper Size	B [in]	C [in]	D [in]	E [in]	F [in]	G [in]	H [in]	I [in]	K [in]	L [in]	N [in]	Clamping range [in]	Torque on wrench [lb/ft]	Gripping force per jaw [lbf]	Max. rpm	Weight [lbs]
7-859-6150	4347-16"-8-5.3" HD	16.34	8	5.50	5.35	6.75	1.00	2.00	5.71	6.07	2.98	0.71	2.36	0.75	1.77 - 15.75	259	7,190	1,200	300
7-859-6153	4347-16"-11-6.5" HD	16.34	11	7.75	6.61	9.25	1.19	2.39	5.71	6.07	2.98	0.71	2.36	0.75	1.77 - 15.75	259	7,190	1,200	282
7-859-6200	4347-20"-8-5.3" HD	19.69	8	5.50	5.35	6.75	1.00	2.00	5.71	6.07	2.98	0.87	2.36	0.75	1.77 - 19.69	259	7,190	1,000	467
7-859-6203	4347-20"-11-6.5" HD	19.69	11	7.75	6.61	9.25	1.19	2.39	5.71	6.07	2.98	0.87	2.36	0.75	1.77 - 19.69	259	7,190	1,000	452
7-859-6839	4347-28"-11-7.5" HD	27.95	11	7.75	7.56	9.25	1.19	2.39	6.10	6.58	3.57	0.87	2.95	0.87	2.95 - 27.95	331	9,217	750	992