

1
2
3
4
5
6



3975



- High precision collet chucks
- TRU-LENGTH - fixed collet position
- Plain back mounting
- The wrench operated scroll provides for uniform and distortion free clamping of workpieces while simultaneously allowing for a fast collet exchange
- Designed for use with 5C collets (385E) and can be used for turning, facing, boring, grinding and milling operations
- Collet 5C or 16C not included

Standard accessories



Spare parts 99-141

Technical data 142-148

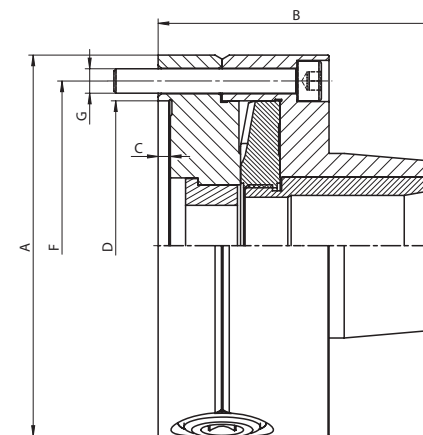

Code No.	Type	A [in]	B [in]	C [in]	D [in]	F [in]	G	RPM	Weight [lbs]
7-862-0503	3975-5"-5C	4.92	3.62	0.16	3.74	4.25	3xM8	6,000	11.46
7-862-0551	3975-5.5"-16C	5.51	4.51	0.16	4.13	4.72	6xM8	6,000	16.31
7-862-0601	3975-6"-16C	6.30	4.51	0.16	4.92	5.51	3xM10	6,000	20.5

Collets available on page 357



3984



- 5C collet chucks
- Direct threaded mount
- The wrench operated scroll provides for uniform and distortion free clamping of workpieces while simultaneously allowing for a fast collet exchange
- Designed for use with 5C collets (385E) and can be used for turning, facing, boring, grinding and milling operations
- Collet 5C not included

Standard accessories



Spare parts 99-141

Technical data 142-148

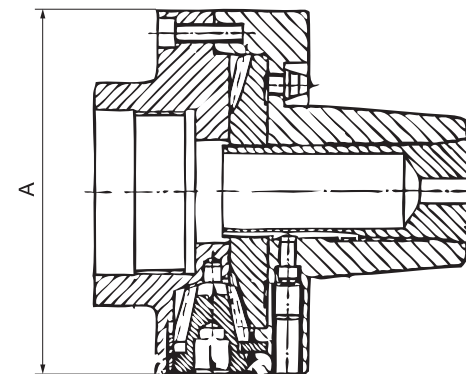

Code No.	Type	A [in]	Thread size	RPM	Weight [lbs]
7-862-0515	3984-5"-5C	4.92	1-1/2" x 8	6,000	12
7-862-0517	3984-5"-5C	4.92	2-1/4" x 8	6,000	12

Collets available on page 357