

- 1
- 2
- 3
- 4
- 5
- 6

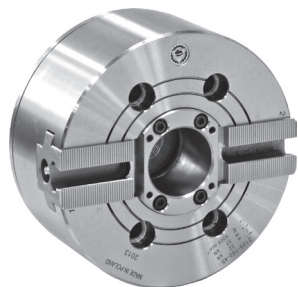

2105-A

INTERCHANGEABLE WITH
SMW-AUTOBLOK TYPE BH-D



- Manufactured from high grade alloy steel which extends machine life while providing higher rigidity and greater wear resistance
- The drawbar design results in its rigid structure and enables direct power transmission to the master jaws in direct area of jaw guideways – effective counteracting of the loss of gripping force and resulting in high power transmission efficiency
- Hardened and ground working surfaces ensure longer life with maintained accuracy and repeatability
- Master jaws secured against throw-off
- Master jaws lubricated directly
- Unbalance G 6.3

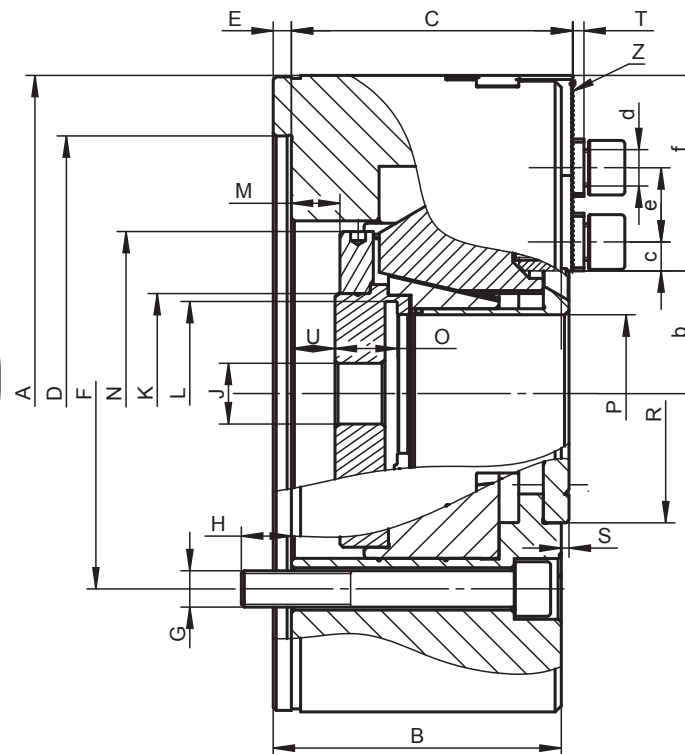
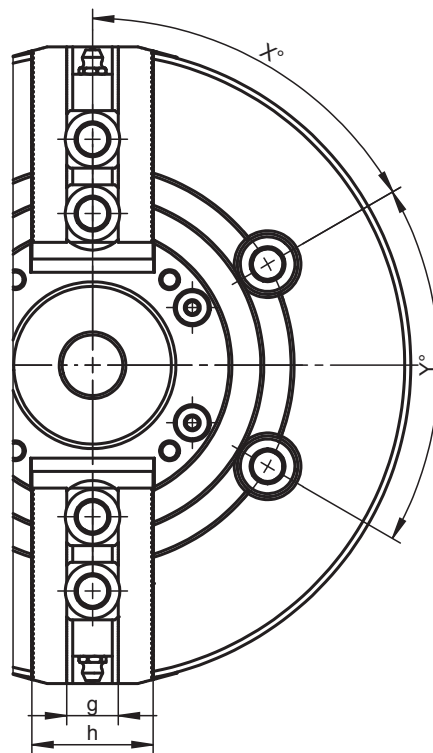

Standard Accessories

Soft Top Jaws

T-nuts interchangeable with SMW-Autoblok

Mounting screws for chuck and jaws

Eye bolt (for Ø >200mm)

2105-A



Type of mounting



Number of jaws



Serration

Code No.	7-762-0600	7-762-0800	7-762-1000	7-762-1200
Type	2105-160-45A	2105-200-52A	2105-250-75A	2105-315-95A
A [mm]	169	210	254	315
B [mm]	81	95	106	108
C [mm]	79	93	104	106
Mounting D H6 [mm]	140	170	220	300
E [mm]	6	6	6	6
F [mm]	104.8	133.4	171.4	235.0
G [mm]	4 x M10	4 x M12	4 x M16	6 x M20
H [mm]	13.5	16.5	18	25
J [mm]	20	20	25	25
K [mm]	60	66	94	111
L max. [mm]	M55 x 2.0	M60 x 2.0	M85 x 2.0	M102 x 2.0
Max. drawbar stroke M [mm]	16 (13/-3)	22.5 (16/-6.5)	27 (19.5/-7.5)	27 (23/-4)
N [mm]	91	107	142	155
O [mm]	19	20.5	25	28
P [mm]	45	52	75	95
R [mm]	70	92	117	138
S [mm]	2.6	2.6	2.6	0.6
T [mm]	3	3.5	3.5	3.5
U [mm]	11/-5	14.5/-8	8.5/-18.5	8/-19
X [mm]	60°	60°	60°	30°
Y [mm]	60°	60°	60°	60°
Jaw stroke a [mm]	3.5	5	6	6
Serration [in]	1/16"x90°	1/16"x90°	1/16"x90°	1/16"x90°
b min. [mm]	30.2	35.5	47.9	58.9
b max. [mm]	33.7	40.5	53.9	64.9
c min. [mm]	9	9.5	12.4	12.5
c max. [mm]	25	33	41	50
d [mm]	M10	M12	M16	M16
e [mm]	24	24.5	32	32
f [mm]	51	64.5	73	94
g H7 [mm]	17/14	17	21	21
h [mm]	38	40	45	52
Max. pulling force [kN]	15	25	31	38
Max. clamping force [kN]	38	62	80	96
Max. speed [rpm]	6,000	5,000	4,200	3,300
Moment of inertia [kgm ²]	0.056	0.165	0.315	0.779
Weight without top jaws [lbs]	26.46	48.50	77.16	121.25

Larger sizes available upon request!