

## ANSI B5.50/CAT TAPER

Standard features of the tools:

- Manufactured with Chrome Manganese steel
- Carburized with depth of case 0.7 mm
- Hardened and precision ground
- Surface hardness HRC 58±2
- Taper angle: tolerance AT3

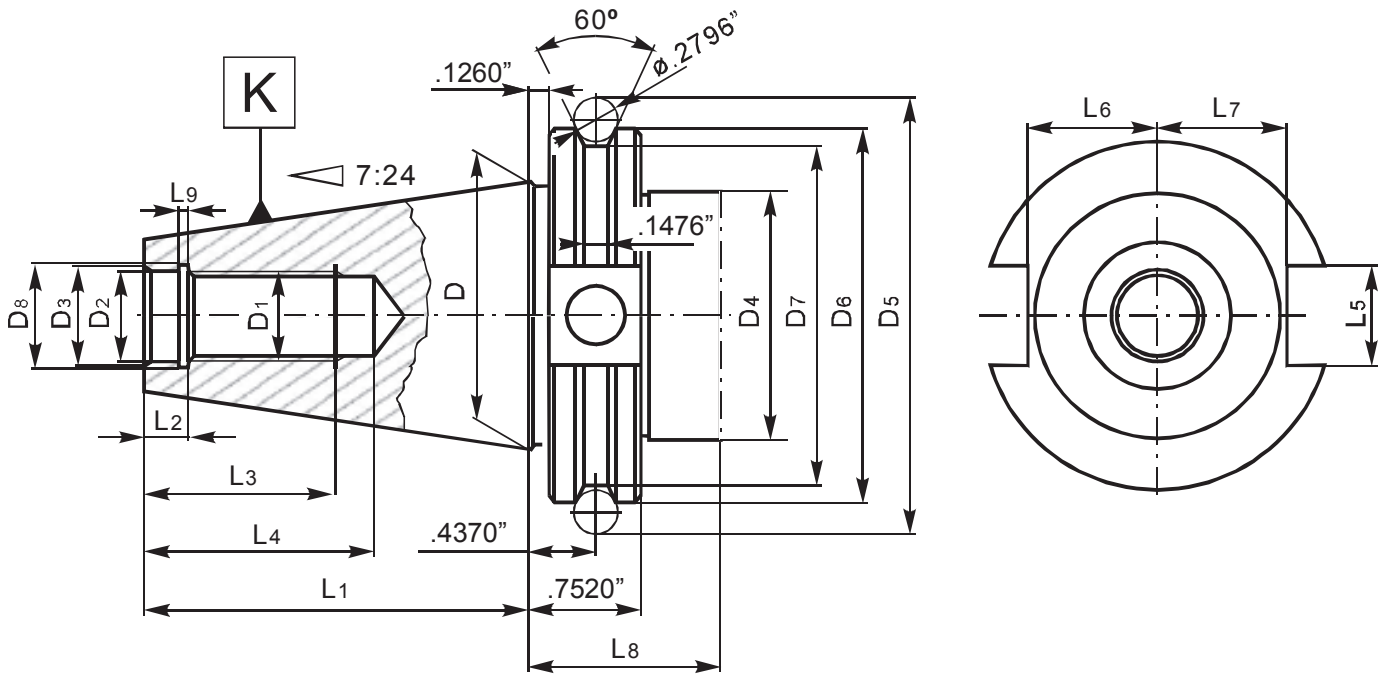

Taper	Measure	D	D2 H8	D3	D4 ±0.002"	D5 ±0.002"	D6 -0.004"	D7 -0.02"	D8	L	L2	L3	L4 min.	L5 ±0.01"	L6	L7	L8 min.	L9
40	inches	1.7500	0.6409	0.7205	1.7500	2.8457	2.5020	2.2287	0.6690	2.6929	0.2170	1.2598	1.6614	0.6449	0.9843	0.8898	1.3858	0.0394
40	mm	44.75	16.28	18.30	44.45	72.28	63.55	56.61	17.00	68.40	5.50	32.00	42.20	16.38	25.00	22.60	35.20	1.00
50	inches	2.7500	1.0307	1.1220	2.7500	4.2209	3.8772	3.5925	1.0630	4.0060	0.2760	1.8504	2.4213	1.0197	1.4843	1.3898	1.3858	0.0394
50	mm	69.85	26.18	28.50	69.85	107.21	98.48	91.25	27.00	101.75	7.00	47.00	61.50	25.90	37.70	35.30	35.20	1.00