

1
2
3
4
5
6

8814 NC

- High speed NC extended revolving centers with 60° point

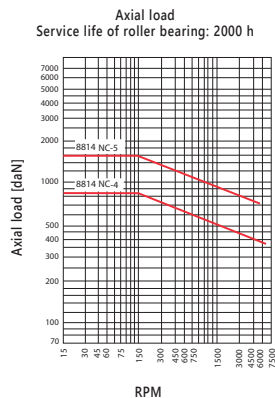
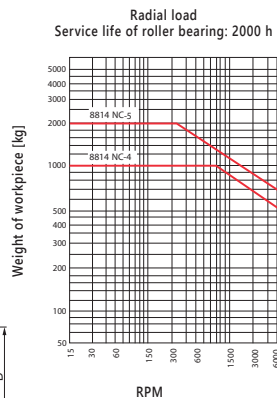
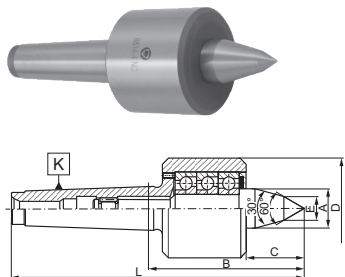

K	MT	Max. weight [lbs]	RPM	Max. concentr. error		Code No.	A [in]	B [in]	C [in]	D [in]	E [in]	L [in]
				[in] Precision	[in] Standard							
4		2,200	7,000	0.0002	0.0004	7-566-004	1.10	4.67	1.93	2.76	0.55	8.70
5		4,400	6,000	0.0002	0.0004	7-566-005	1.57	5.93	2.66	3.74	0.63	11.02

8815 NC

- High speed NC extended revolving centers with 60° point and draw off nut

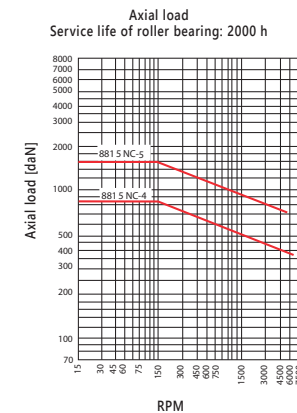
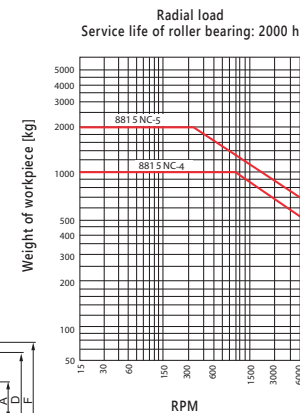
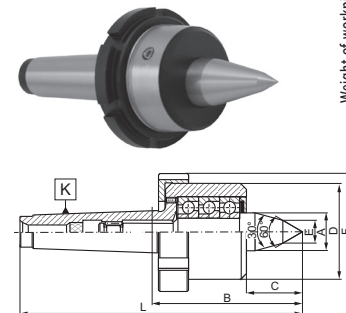

K	MT	Max. weight [lbs]	RPM	Max. concentr. error		Code No.	A [in]	B [in]	C [in]	D [in]	E [in]	F [in]	L [in]
				[in] Precision	[in] Standard								
4		2,200	7,000	0.0002	0.0004	7-569-004	1.10	4.67	1.93	2.76	0.55	3.23	8.70
5		4,400	6,000	0.0002	0.0004	7-569-005	1.57	5.93	2.66	3.74	0.63	4.33	11.02

8824

8823

8815 NC

8814 NC

8823

- Radial compensation revolving centers with 60° point

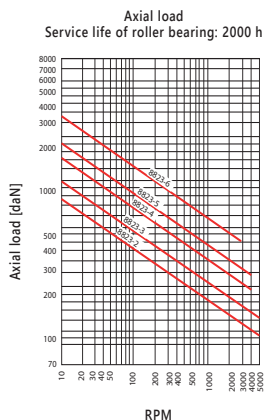
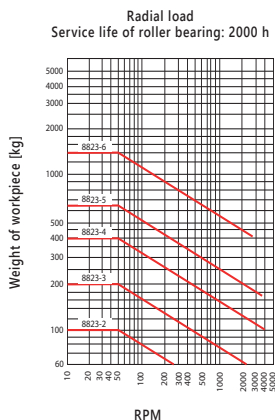
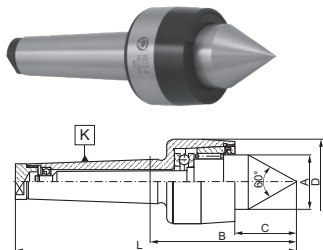

K	MT	Max. weight [lbs]	RPM	Max. concentr. error		Code No.	A [in]	B [in]	C [in]	D [in]	L [in]
				[in] Precision	[in] Standard						
2		220	8,000	0.0002	0.0002	7-567-002	0.94	2.87	1.04	1.73	5.41
3		440	6,000	0.0001	0.0002	7-567-003	1.10	3.35	1.28	1.89	6.54
4		880	4,500	0.0001	0.0002	7-567-004	1.50	3.72	1.71	2.36	7.74
5		1,430	4,000	0.0001	0.0002	7-567-005	1.97	4.59	2.19	2.95	9.69
6		3,080	3,000	0.0001	0.0003	7-567-006	2.38	5.31	2.46	3.54	12.48

8824

- Radial compensation revolving centers with 60° point

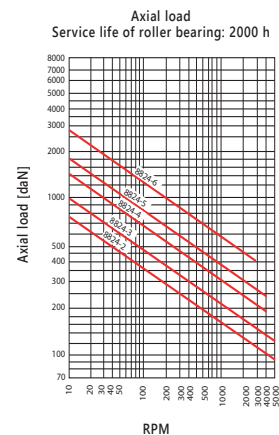
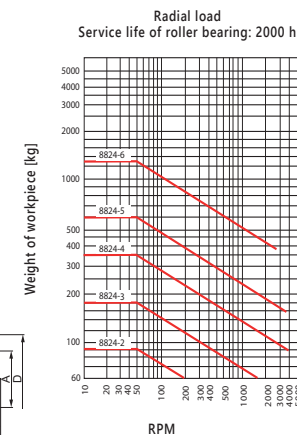
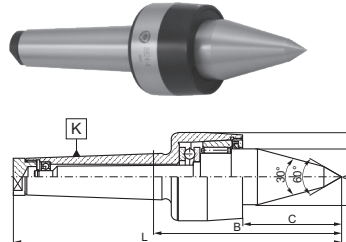

K	MT	Max. weight [lbs]	RPM	Max. concentr. error [in] Precision	Code No.	A [in]	B [in]	C [in]	D [in]	L [in]
3		396	6,000	0.0006	7-559-003	1.10	3.94	1.87	1.89	7.13
4		770	4,500	0.0006	7-559-004	1.50	4.63	2.62	2.36	8.64
5		1,320	4,000	0.0006	7-559-005	1.97	5.81	3.41	2.95	10.91
6		2,860	3,000	0.0006	7-559-006	2.38	6.57	3.72	3.54	13.74